



**FPPoschner GmbH & Co KG**  
Anlagentechnik  
Tel. 03382-52420-0  
Fax. 03382-52420-4  
A 8280 Fürstenfeld Grazerstrasse 9



**FIBC UNLOADER**  
**BIG BAG - ENTLEERSTATION**  
**DECHARGEUSE DE BIG BAG**  
**SVUOTA BIG - BAG**

**SBB**

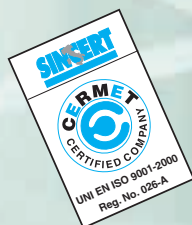

The following problems are normally encountered when unloading FIBCs:

- Dust is produced when the bag is opened.
- Difficulties occur when trying to remove substances from the bag which have been compressed during transportation or storage.
- Substances remain trapped in the corners of the bag, making it necessary for the subsequent unloading to be carried out by hand.

In order to avoid such problems we suggest you use our modular unloading system. Such systems can be expanded and a range of accessories is available which is guaranteed to satisfy every individual requirement with unrivalled efficiency, simplicity and cost.

Standard material: carbon steel  
On request: 304 or 316 stainless steel

Beim Entleeren von Big-Bags treten oft Probleme auf wie

- Staubentwicklung beim Öffnen des Big-Bags
- Big-Bag läßt sich nicht vollständig entleeren, weil sich das Produkt durch Transport oder längere Lagerung stark verdichtet hat
- In den Ecken des Big-Bags befinden sich Produktreste, die von Hand entfernt werden müssen

Bei der Big-Bag-Entleerstation vom Typ SBB werden diese Probleme dank eines Konzepts, welches insbesondere auf individuelle Kundenbedürfnisse eingeht, bereits im Vorfeld vermieden. Die Modulbauweise und eine breite Auswahl an Zubehör bieten effiziente und wirtschaftliche, vor allem aber anwenderfreundliche Lösungen.

Standardausführung aus Stahl  
Auf Wunsch Ausführungen aus Edelstahl 1.4301 oder 1.4401

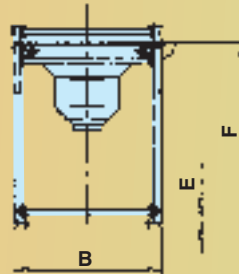
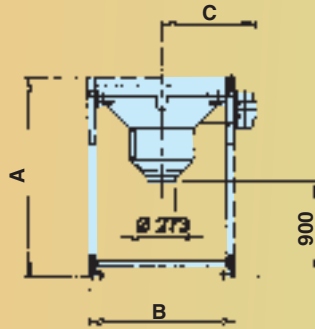
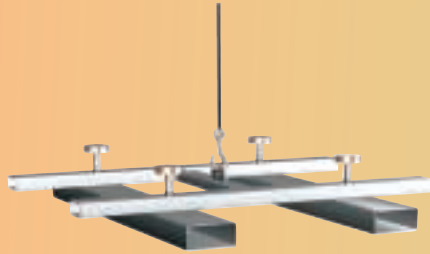

Type	A	B	C	E	F
SBB.125.C	1914	1400	832	100	1734
SBB.150.C	2490	1800	1047	160	1880

Dimensions in mm

Type	A max.	B	C	D	E
SBB.125.S	3960	1400	832	130	1000
SBB.150.S	4307	1800	1047	180	1600

Dimen



Au moment de la vidange des Big Bag, il se posent généralement les problèmes suivants:

- Dégagement des poussières à l'ouverture du sac
- Extraction difficile des produits dûe au tassement généré par le transport ou le stockage
- Opération manuelle supplémentaire pour vider complètement les sacs du produit restant dans les angles.

Pour éliminer ces inconvénients, nous vous proposons un système de déchargement modulaire et expansible, accompagné de toute une gamme d'accessoires qui permettent de satisfaire aux demandes spécifiques. Ce système est efficace, simple et économique.

Fabrication de série: en acier au carbone  
sur demande: en inox AISI 304-316

Alcuni dei problemi che si manifestano durante le fasi di svuotamento dei Big Bag sono:

- Emissione di polvere durante l'apertura della bocca
- Svuotamento parziale dei sacconi che contengono prodotti compattati.

Al fine di evitare gli inconvenienti sopra esposti proponiamo un sistema di svuotamento modulare ed espandibile completo di una gamma di accessori che consente di soddisfare richieste specifiche con ineguagliabile efficienza, semplicità ed economicità.

Esecuzione standard: acciaio al carbonio  
A richiesta: AISI 304-316

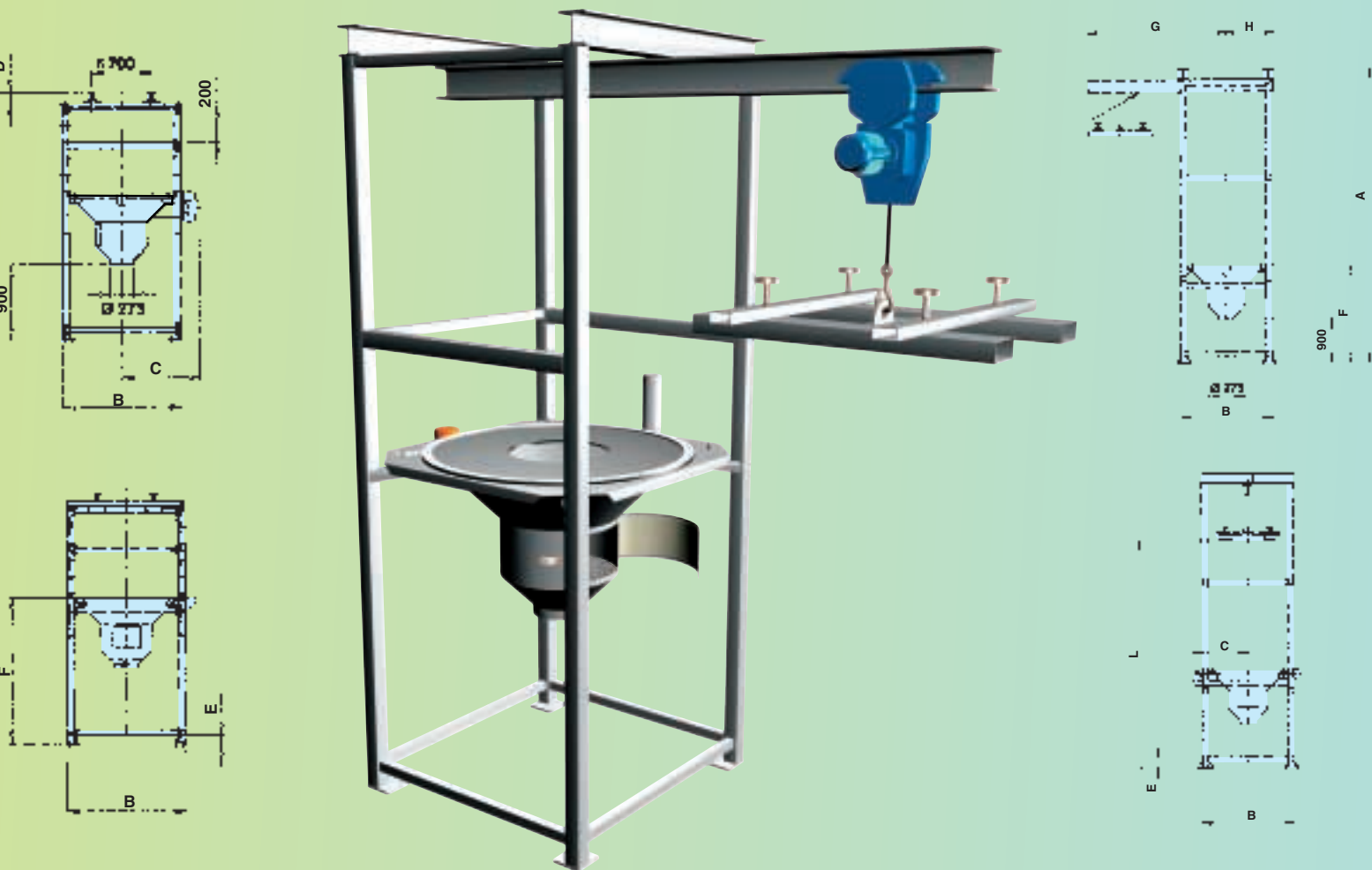

	F
Ø	1734
Ø	1880

Type	A	B	C	E	F	G	H	L
SBB.125.M	4810	1400	832	160	1734	2150	750	3765

Dimensions in mm

Dimensions in mm



WITH ROTARY VALVE  
MIT ZELLENRADSCHLEUSE  
AVEC VANNE ALVEOLAIRE  
CON ROTOVALVOLA



WITH PNEUMATIC CONVEYING SYSTEM  
MIT PNEUMATISCHEM FÖRDERSYSTEM  
AVEC TRANSPORT PNEUMATIQUE  
CON TRASPORTO PNEUMATICO



WITH MICRO-BATCH FEEDER  
MIT MIKRODOSIERER  
AVEC MICRODOSEUR  
CON MICRODOSATORE

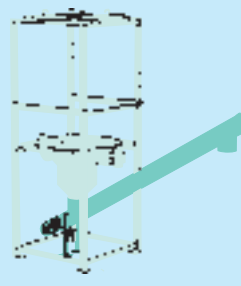

WITH TUBULAR SCREW FEEDER  
MIT DOSIERSCHNECKE  
AVEC VIS TUBULAIRE  
CON COCCLEA TUBOLARE

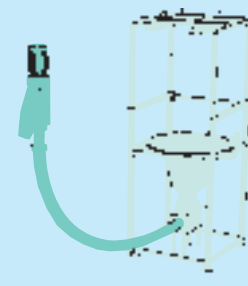

WITH FLEXIBLE HELIX CONVEYOR  
MIT FLEXIBLER SCHNECKE  
AVEC VIS FLEXIBLE  
CON COCCLEA FLESSIBILE



CUTTING SYSTEM  
 SCHNITTVORRICHTUNG  
 SYSTEME DE COUPE  
 SISTEMA DI TAGLIO



PNEUMATIC  
 SHAKING SYSTEM  
 PNEUMATISCHE  
 SCHÜTTELVORRICHTUNG  
 SYSTEME PNEUMATIQUE  
 DE SECOUEMENT  
 SISTEMA DI SCUOTIMENTO  
 PNEUMATICO



PRODUCT RANGE  
 LIEFERPROGRAMM  
 GAMME PRODUZIONE  
 GAMMA PRODUZIONE



N.B.: Rights reserved to modify technical specifications.

N.B.: Angaben ohne Gewähr. Änderungen können ohne Vorankündigung vorgenommen werden.

N.B.: Toutes données portées dans le présent catalogue n'engagent pas le fabricant. Elles peuvent être modifiées à tout moment.

N.B.: Tutti i dati riportati nel presente catalogo non sono impegnativi e possono subire variazioni in qualsiasi momento.

